

Solid Edge motion simulation, explode – render – animate

www.siemens.com/solidedge

white paper



- ▶ Integrated explode, render and animation capabilities, combined with motion simulation, allow you to create dynamic photorealistic animations and motion studies using existing Solid Edge® software 3D models to share and articulate design ideas, reduce risk and generate new business.

PLM Software

Answers for industry.

SIEMENS

Table of contents

Introduction	1
Full motion simulation	2
Explode – render – animate	3
Explode – clear visualization	3
Animation – bringing your designs to life	4
Render – adding the finishing touch	4
Conclusion	5
Commands, features and workflows	5
Smartstep	5
Motion studies	5
Explode	7
Animation	8
Advance rendering with Virtual Studio+	8

► Introduction

Many companies already recognize the benefits of using 3D for design work. Solid Edge goes beyond building assemblies and allows companies to extend their CAD data to be used by design review teams, communicate and market their products, help manufacturing and instruct shop floor assembly workers and field engineers.

- Design review teams collaborate and share their products and ideas
- Project engineers/leaders visualize, communicate and market products internally or with customers and use engineering data to visualize designs and fix errors before building expensive physical prototypes
- Manufacturing engineers and process planners define tooling and production process, communicate design intent and manufacturing sequences (assembly/disassembly) to shop floor
- Service teams create interactive animations of products using Solid Edge assemblies to train shop floor assembly personnel, co-workers and field engineers, as well as using engineering data to quickly produce technical publications for service and repair manuals

This white paper explores these powerful communication and collaboration capabilities in more detail – how they function, how they all work together and help you articulate your design ideas and collaborate within your organization and your partners throughout the design process.

Design collaboration across all points of the value chain

Globally distributed partner networks are no longer the sole domain of large OEMs. It is now common for small and mid-size companies to participate in or even drive multiple, highly competitive supply chains, each placing rigorous demands on product development speed, quality and costs.

Collaboration is critical to successful product design, and with Solid Edge, OEMs and suppliers can improve and manage collaboration across design teams, regardless of location. By reducing design revisions and communication delays, our customers enjoy quicker time-to-market and increased profitability.

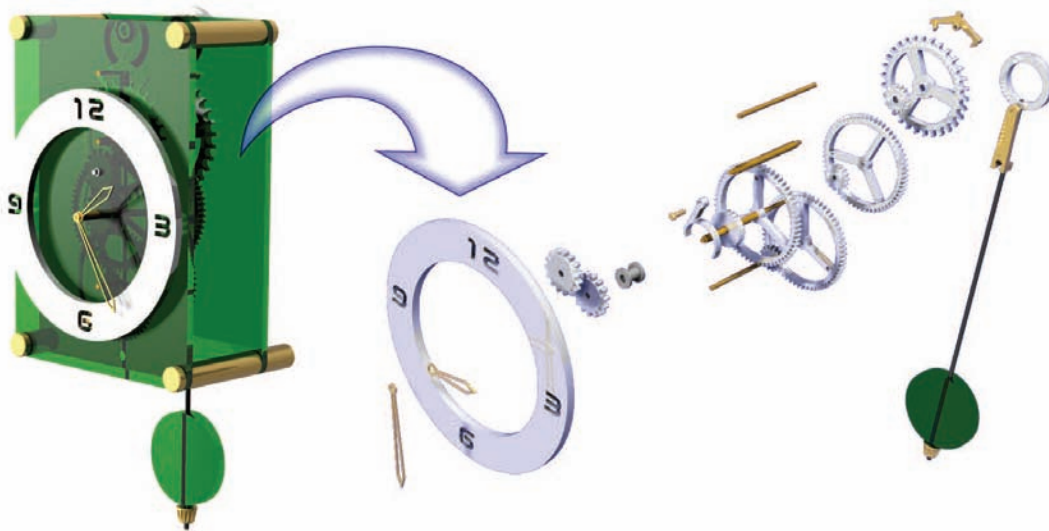

The separate capabilities outlined in this white paper are designed to be used independently or in combination with each other. This may or may not be by the same person. For example, designers are able to carry out motion studies that prove a design functions and all the events are automatically captured. Later someone might explode an assembly to be used in a technical publication. The exploded assembly could then be used to show the assembly/disassembly sequence, including motion if desired using the advanced animation editor to set timing, position duration, fade parts in and out and more. Solid Edge can render these animations quickly using the standard Solid Edge shading. For marketing and other purposes, Solid Edge Virtual Studio+ can be used to capture frame by frame animations that include scenery, textures, advanced lighting, shadows and more to create really high quality movies.

► Full motion simulation

The motion simulation tools in Solid Edge allow you to create automated, accurate and realistic conceptual motion studies during your design phase, animating designs to demonstrate and communicate product functionality – in real time. These capabilities allow you to quickly and easily define motion relationships between gears, pulleys and hydraulic cylinders while applying motors to initiate motion.

Motion simulation in Solid Edge combines advanced gear and motor relationships with a timeline control that allows design engineers to check for full range of motion, clearance and collisions automatically using a 3D virtual mockup early in the design stage when changes are relatively easy and costs are manageable.

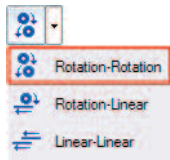

Gears are enhanced assembly relationships. They work by determining a relationship (or ratio) between adjacent parts, such as gears and pulleys. Gears efficiently solve motion between related components without the need to define physical contact relationships. They can be used to describe rotary to rotary (gears), rotary to linear (rack and pinion) or linear to linear (telescopic or hydraulic cylinder) type relationships.



Motors complement gear relationships by driving a gear through its range of motion – rotary or linear. Usually you only need one motor to drive a gear train. After applying a motor to the driving gear, the gears themselves solve the rest of the motion.

A dedicated motion editor or *timeline* automatically captures motor events as they are created and allows you to easily control motor properties such as direction, speed and travel. This timeline also provides a graphical interface that allows you to quickly drag and drop motor properties to adjust when a motor should start, or to increase or reduce how long a motor should run.

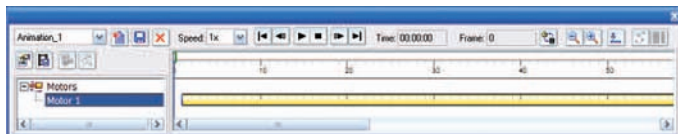
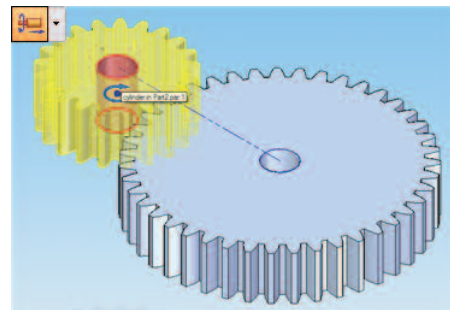

► Explode – render – animate

It is one thing for engineers to be able to create motion studies and check for design errors using Solid Edge. But to truly communicate and share your designs outside of the engineering department and bring your designs to life, you need a little more from your 3D design system.

Explode – render – animate (ERA) capabilities included in Solid Edge allow mechanisms to be in motion while exploded views depict your design being assembled or disassembled. At the same time you are able to control camera angle and position, zoom in for close up views of important details and apply photo realistic rendering settings to create exceptional animations that help sell your products and communicate your designs.

Explode – render – animate can be used to produce dynamic documentation that helps communicate ideas and designs to nonengineers, create technical illustrations in maintenance and repair manuals for field engineers and communicate clearer assembly manufacturing instructions and training videos for the shop floor, using dynamic 3D motion, AVI movies and technical illustrations.

Explode – clear visualization

To help visualize designs and expose the internal workings of machines, engineers have been using the technique of creating exploded views on their drawings. Using 2D is a time consuming task – usually meaning every component needs to be redrawn in isometric. Exploding a 3D virtual mockup using Solid Edge opens up many more opportunities and re-uses design data already captured.

Solid Edge can automatically explode your assemblies using logic based on assembly constraints and default spread distance to quickly explode your designs. Manual controls can be used to adjust spread distance and reposition components. Flow lines are automatically created so you can easily visualize where components have been exploded relative to adjacent parts.

The sequence and default time it takes to spread the parts being exploded are automatically captured in an advanced timeline called the 'animation editor'. They can be easily adjusted later by dragging the events in the animation editor.

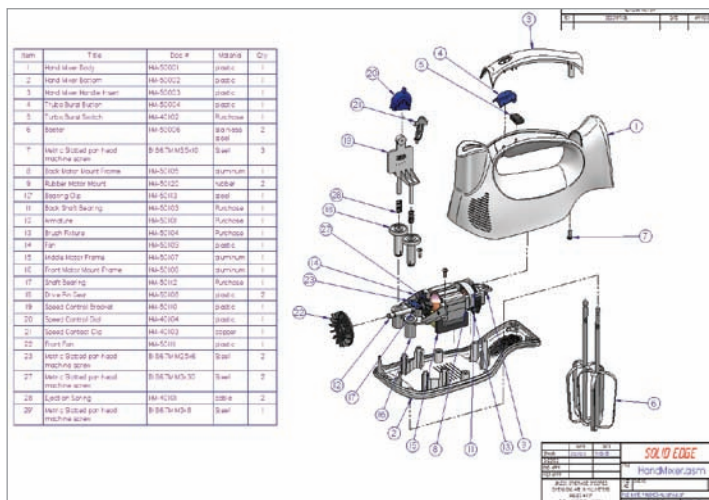
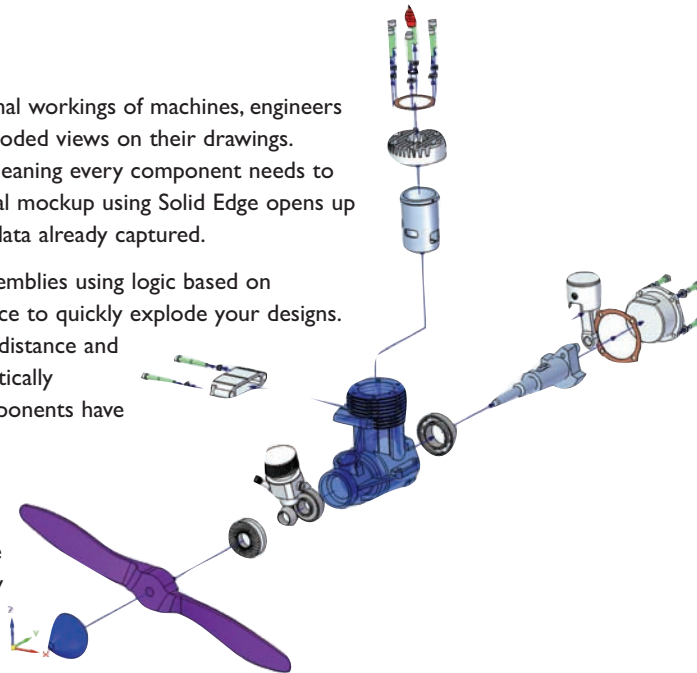

Exploded views can also be saved as a configuration and used to create pictorial views on drawing sheets that depict exploded assemblies with associated parts lists that are commonly used by technical illustrators in maintenance and repair manuals.

Animation – bringing your designs to life

All of your motion study and explode events are captured in the animation editor. The animation editor provides precise control over duration, timing and position of all captured motion and explode events, camera and component paths and appearance. For added clarity, camera paths can be easily created to view your designs from the best vantage point, including closeup views on important details and true 'fly through' and 'fly around' capabilities.

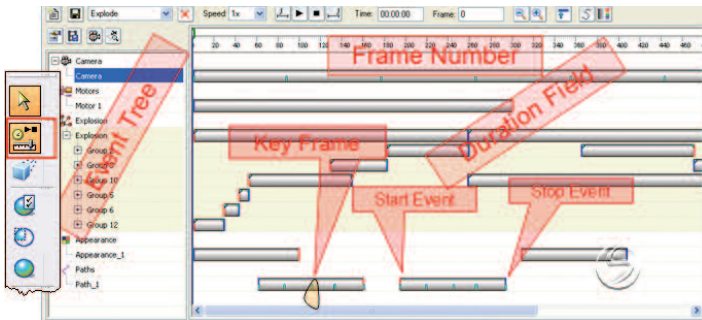

3D component paths can be added to allow components to be moved anywhere in your design environment over and above the automatic exploded view paths.

For more realism, and to add impact to your animations, face styles and textures can be changed during the animation as well as fading components in or out to emphasize or deemphasize their importance.

Render – adding the finishing touch

Solid Edge Virtual Studio+ is an integrated advanced rendering application that allows your Solid Edge designs to be transformed into photorealistic images. These images are ideal for use in sales and



marketing collateral – allowing you and your customers to visualize a final product before manufacturing or fabrication occurs.

Virtual Studio+ is included with Solid Edge Classic, and allows you to render your images quickly and accurately at any stage in your design process. By providing you with the ability to simulate a wide range of sophisticated materials, colors, textures, scenes and real lighting situations, Solid Edge Virtual Studio+ lets you create high-quality photorealistic renderings of 3D parts or assemblies at light speed. The latest technologies for generating artistic-based renderings for a pencil drawn look are also part of Solid Edge Virtual Studio+.

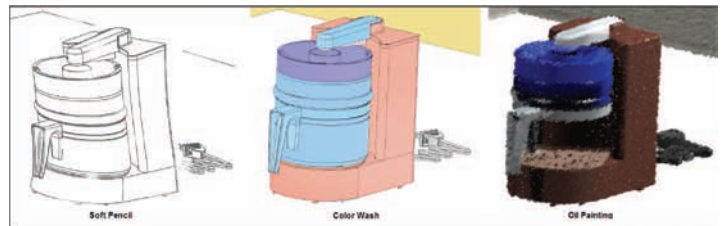

Once your animation is set up the way you want, you are able to output AVI movie files that are easy to share among your colleagues using standard media players such as Windows Media Player and QuickTime. The AVI format mainly depends on the codec's you have installed. Solid Edge supports all the formats delivered free with Windows XP.

Standard face styles are the default setting and provide great quality for most purposes, but if you require a higher standard to impress a customer, Solid Edge Virtual Studio+ can be used to add textures, lighting effects, scenery and more to capture frame by frame animations to create photorealistic renderings to write to AVI movies.

► Conclusion

The combination of process-specific motion simulation with explode, render and animation capabilities in Solid Edge allows you to promote your designs internally, helps you win new business, communicate manufacturing information with dynamic documentation to train shop floor, service and maintenance teams, create technical publications for service and repair manuals and generate photorealistic full motion AVI's that help market and evaluate your products.

► Commands, features and workflows

The remainder of this document explores some of the specific commands, features and workflows that make Solid Edge's dynamic documentation capabilities such a powerful collaboration tool.



Smartstep

The Solid Edge Smartstep facilitates a process-oriented workflow, and guides you through the process of creating gears, motors, exploded assemblies etc. Smartstep dynamically changes to reflect which tools you are using. For example, when the gear relationship type is set to rotation to rotation, the dropdown list becomes active to allow the user to select either ratio or number of teeth. The gear ratio will be automatically calculated based on the number of teeth.

Motion studies

Gear types – motion enablers

There are three main gear types, rotation to rotation, which are used for circular gears; rotation to linear, which can be applied to a rack and pinion; and linear to linear, used for hydraulic cylinders or assemblies with a telescopic action. For this exercise choose rotation-to-rotation.

Rotation to rotation – The axes between two components can be at any position in 3D space. The axes need not be parallel or perpendicular to each other and do not need to be touching.

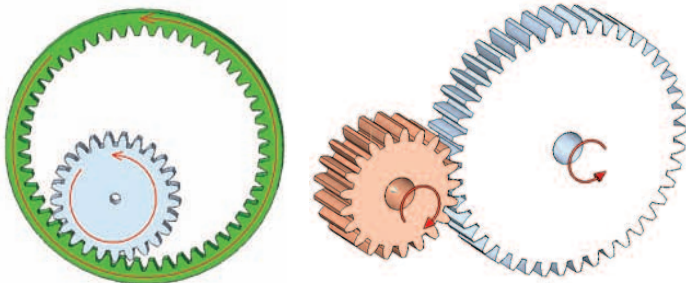

Rotation to linear –

The axes between two components can be at any position in 3D space. The axis and translation vector need not be parallel or perpendicular to each other and need not be touching.

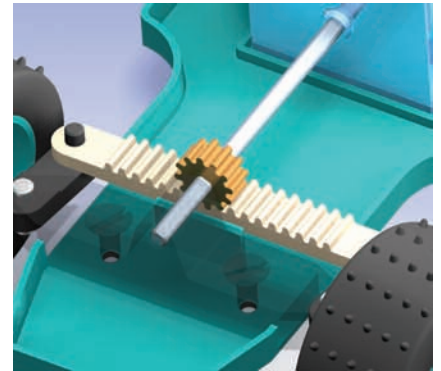

Linear to linear –

The axes between two components can be at any position in 3D space. The translation vectors need not be parallel or perpendicular to each other and need not be touching. For example: the 3 inch cylinder transfers fluid to the 1 inch cylinder and it translates at a faster rate than the 1 inch cylinder since it is 1/3 the diameter.

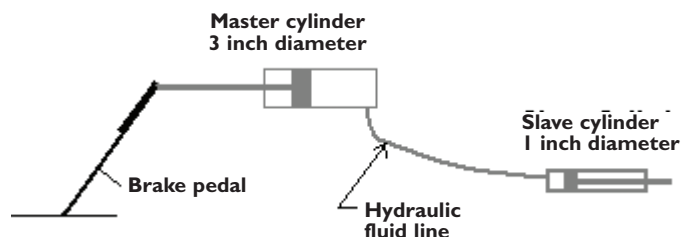

Motors – motion generators

Motors can be defined as rotational or linear types. For rotational motors you are able to set the rotational velocity and an angular limit used to specify the number of rotations that a rotational motor turns. Linear motors use a linear velocity and a limit to specify the distance of travel for the linear motor once activated. The actual units are based on what units the Solid Edge user has set.

Multiple motors can be applied to the same part. Multiple motors are primarily used so that different motors can be turned on/off in the timeline, for example, a motor could be turned on from zero to 10 seconds to move a component in the x-direction, then turned off and another motor turned on to move the component in the y-direction.

New motors are added to the assembly pathfinder when a motor is defined. There is no limitation on the number of motors that can exist in an assembly.

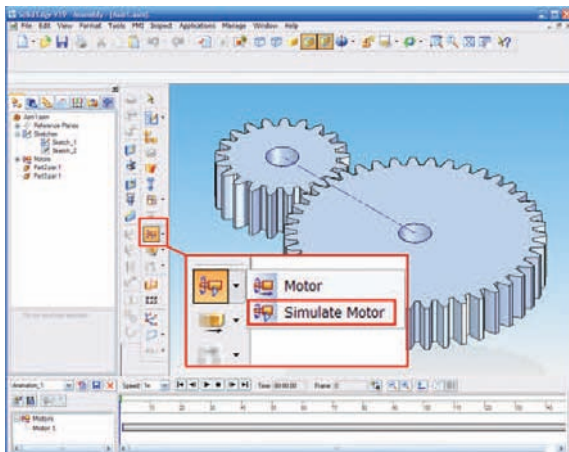
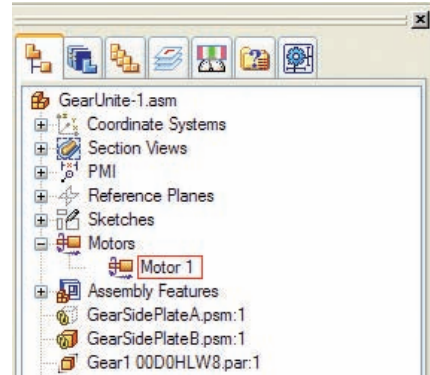

Simulate Motor – Once you have the gear relationships and the motors defined, you are ready to automate your design.

The motion simulation timeline will automatically display. Events and object can then be added as to the timeline. To start the simulation hit the Run button to set your gears in motion. Simply drag the motion duration. For more complex mechanisms, just add more gears as necessary, while maintaining full control over timing and duration. You can also capture your motion study by saving it as an AVI.

Explode

Automatic explode

Automatic explode provides the quickest way to explode your assembly. There are options to explode the entire assembly or to bind subassemblies together. Additional options allow you to adjust the spread

distance or use an automatically calculated distance. Solid Edge also provides manual explode tools for precise control – these can always be used after an automatic explode for final customization.

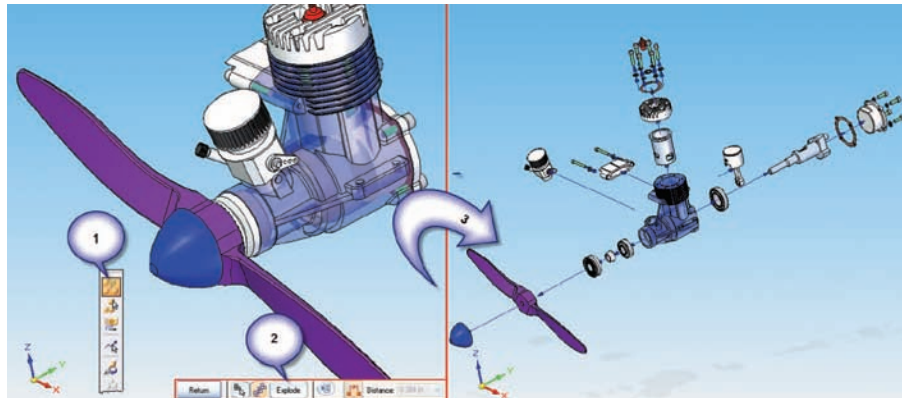

Reposition components

Components that did not automatically explode in the sequence you require are easy to reposition. Select the 'reposition parts' icon from the main tool bar (step 1). Then select the component you want to move (step 2a), next select the new part you want to reposition your part against (step 2b) and your part will reposition (step 3).

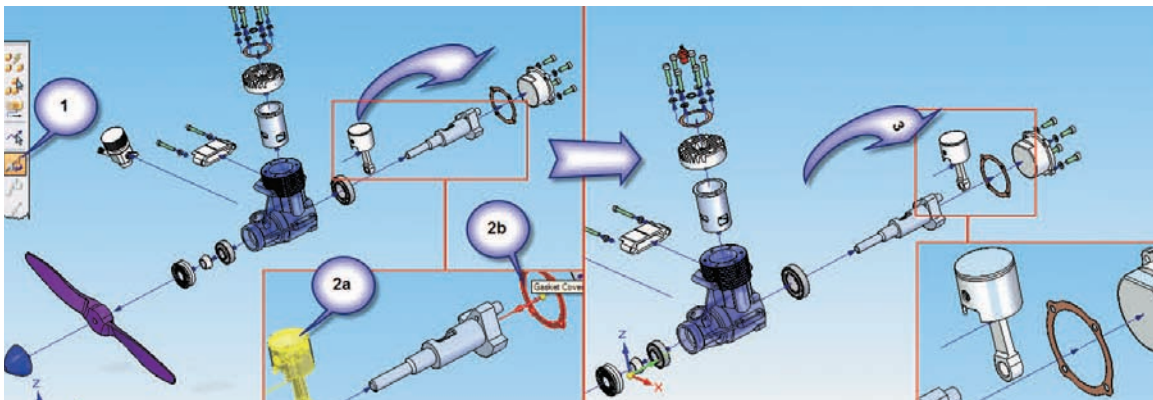

Move component position, flow and jog lines

You can also quickly and easily move components to a new location. Moving components keeps them in the same explode sequence; however, you also have options to move individual and dependent parts.

Start by selecting the 'move part' icon from the main toolbar (step 1). Next choose the part to move and click the right mouse button (step 2). Choose the axis you want to move the part along (step 3).

Now drag your part – note that you can keep choosing different axes until you are happy the part is correctly positioned.

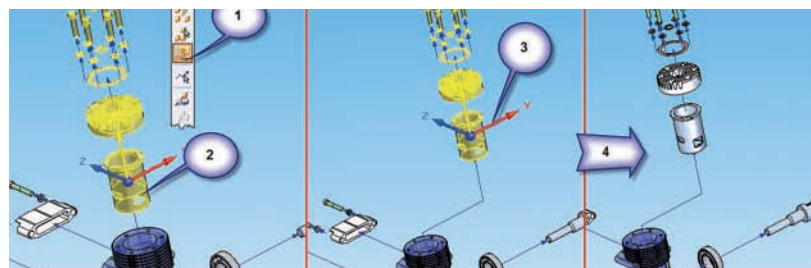

Animation

All these exercises create events. These events include speed, duration, location, position, etc. The animation editor captures all these events and allows you to graphically manage and adjust them to provide you with even more control. The animation editor consists of a timeline, an event tree and other controls for adjusting component appearance (solid, translucent or textured), setting up cameras and flight paths as well as AVI settings and more. To start the animation editor click on the animation editor icon on the main toolbar.

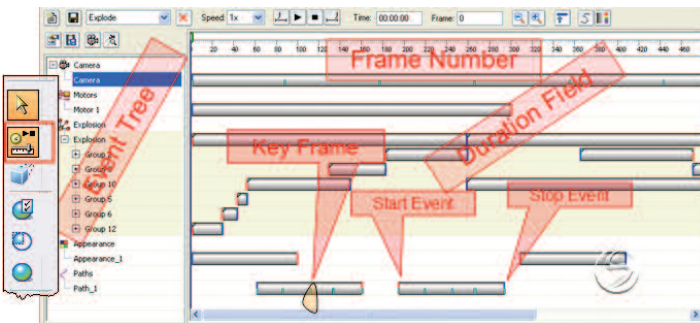

Advance rendering with Virtual Studio+

Extensive materials database

When Virtual Studio+ is activated, two extra tabs are added to the edgebar. The first is used to store and edit the current scene settings. The second tab stores all the predefined materials that can be applied to individual or multiple components with a simple drag-and-drop operation. Textures such as patterns, bumps, wrapped images, grids, stencils and transparencies can also be assigned to specific materials, along with additional user-defined control for color, reflectance, highlight, ambient light effect, roughness and diffuse light effects.

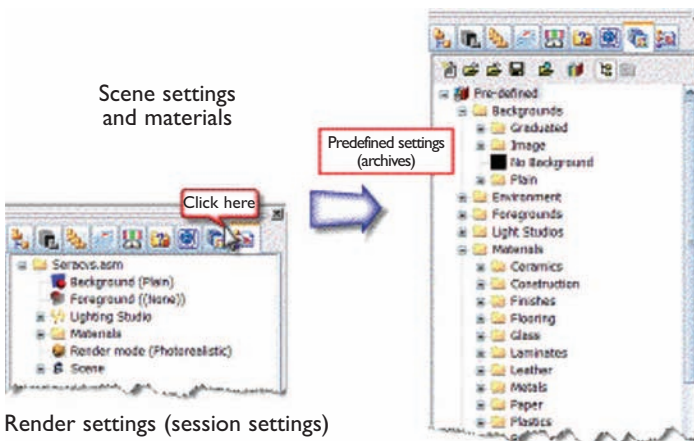

Realistic scenes

From the 'predefined archives' tab you have access to predefined addition of surface colors, materials, textures and transparencies. To add a material to a component, simply select it from the edgebar and drag it to a part. Tip: materials can also be added to several parts simultaneously; select the parts and then use the right mouse button menu over the material to add, and choose 'apply to selected'. To preview the results, click the render scene button.

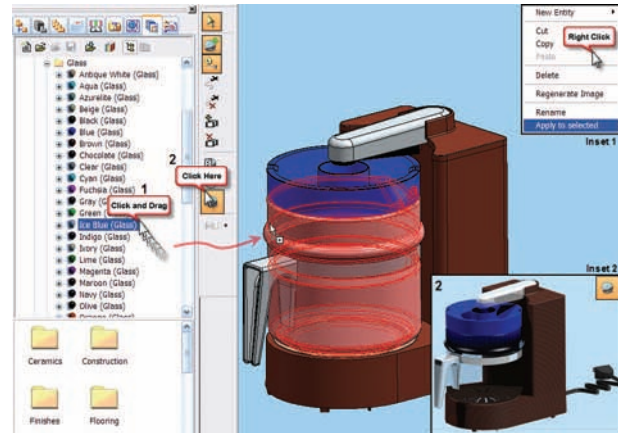

With Solid Edge Virtual Studio+, you can also create realistic scenes that use lighting distribution, hard and soft shadows, foregrounds and backgrounds to simulate the environment in which the product will be used.

Backgrounds can range from simple or graduated color schemes through to custom images, while a variety of foreground modes allow the application of effects such as fog, light scattering medium (such as dust through a bright window) and snow. Realistic scenery such as table tops, tiled floors and water can also be dragged into the view.

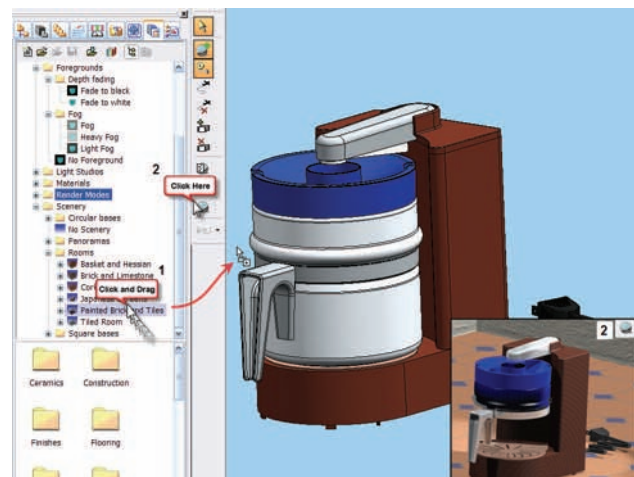

For maximum realism, your product can be placed inside an “environment” consisting of four walls, a top and a base or a cylinder with a top and a base. By applying custom images or materials to each wall of the environment, you can visualize exactly what the product will look like in the situation in which it will be used, including the effects of lights, reflections and shadows. To apply a scene, select the scenery branch from the predefined archive tab, choose a scene and drag it onto the modeling space. To render the scene, click on the render scene button.

To complete your scene, choose from the many interior, exterior and colored light options. You can set the ambient lighting value, simulate the effects for natural sunlight, or add point, spot or distant lighting. Spot and point lights can be positioned anywhere in the scene, and you can control the intensity and luminescence drop-off. The target and illumination cone from the spot light can also be adjusted.

To set up a spot light (there are other types such as ambient, point, spot or sun light), select the ‘lighting studio’ branch from the session

entities tab, click with the right mouse button and select ‘add’ (Figure 5). You can edit the light properties by selecting ‘edit definition.’ To graphically reposition the lights, select the second tab and by clicking and dragging the positioning handles around the light you can easily choose a new position (Figure 5).

For more photorealism, you can control many different effects to fine-tune your images:

- Add transparent or semi-transparent material shadows, such as when light passes through a glass
- Apply anti-aliasing for crisper images
- Adjust radiosity to control the effects of indirect lighting
- Add depth cue fading to simulate the effect of depth of field, with the image fading to a set color
- Light scattering to show light rays reflecting off dust or smoke in a room

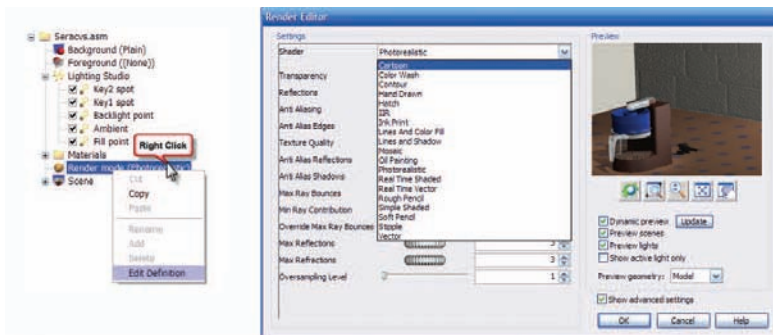
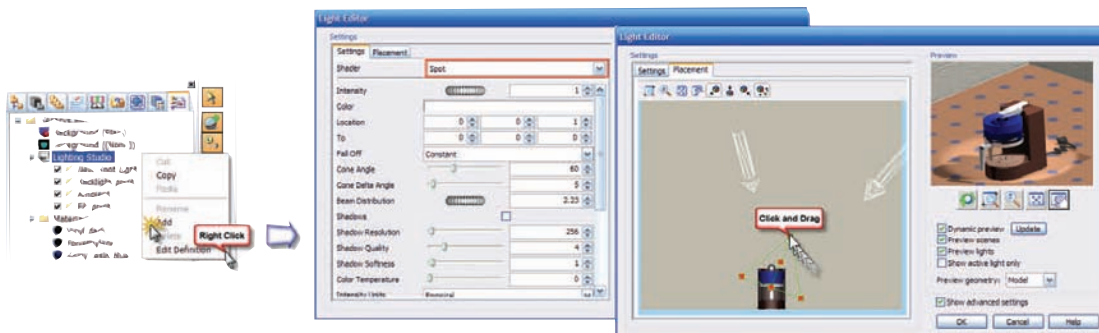

Rendering options for early stage development and concept reviews

Solid Edge Virtual Studio+ lets you create images that are appropriate for the many different stages of the design process. A unique technology allows the easy creation of impressionistic and stylized images to support industrial design-type rendering for early-stage visualization and concept reviews. Designers have the ability to generate a variety of expressionistic effects that make the image appear as if it were done by freehand sketching. There are a number of artistic render modes available, including cartoon and hand drawn. No longer do you need to worry about creating the wrong impression with a full photorealistic image of a mere concept. Sketch-based rendering is just one more example of how Solid Edge matches the right tool for the job at hand. To adjust the render type, right click on the ‘render mode’ branch from the edgebar, select edit definition (Figure 6) and choose a different type of render mode. Don’t be afraid to experiment with all the render types and settings. A live preview will show you how the finished result will look.

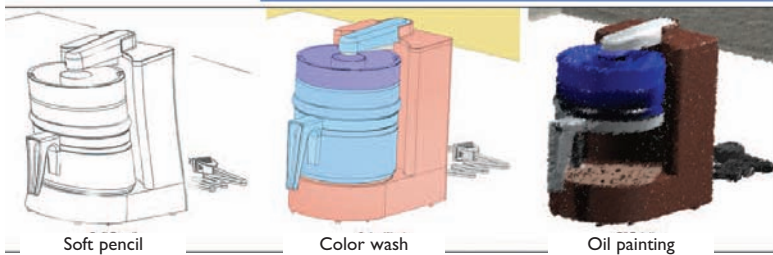

About Siemens PLM Software

Siemens PLM Software, a business unit of the Siemens Industry Automation Division, is a leading global provider of product lifecycle management (PLM) software and services with 5.5 million licensed seats and 51,000 customers worldwide. Headquartered in Plano, Texas, Siemens PLM Software's open enterprise solutions enable a world where organizations and their partners collaborate through Global Innovation Networks to deliver world-class products and services. For more information on Siemens PLM Software products and services, visit www.siemens.com/plm.

► For more information, contact your local Solid Edge representative:



DESTEK
YAZILIM

Destek Yazılım Ltd. Şti.
Barbaros Mah. Denizmen Sk.
No:4/2 Koşuyolu – Usküdar
34662 İstanbul
Tel: (0216) 651 98 01
Fax: (0216) 651 98 02
www.destek-yazilim.com

SIEMENS

Division headquarters

United States

Granite Park One
5800 Granite Parkway
Suite 600
Plano, TX 75024
972 987 3000
Fax 972 987 3398

Solid Edge – www.siemens.com/solidedge

Americas

800 807 2200
Fax 314 264 8922

Europe

44 (0) 1202 243455
Fax 44 (0) 1202 243465

Asia-Pacific

852 2230 3308
Fax 852 2230 3210