

Velocity Series

Solid Edge structural frames and weldments

www.siemens.com/solidedge

white paper

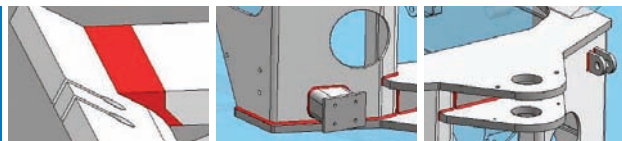

- ▶ Intelligent, process-specific applications that speed time to manufacturing.

PLM Software

Answers for industry.

SIEMENS

Table of contents

Solid Edge structural frames and weldments	1
Solid Edge structural frames	2
Creating the frame skeleton	2
Building the 3D frame	2
Create drawings with cut lists	3
Solid Edge weldments	4
Creation and selection of the weldment	5
Surface preparation	5
Weld bead creation	6
Machining	7
Drawings and documentation	7
The Solid Edge advantage	8
Summary	8

► Solid Edge structural frames and weldments

Solid Edge® software includes two process-specific applications designed specifically to speed the creation of rigid frame structures and weldments, both of which are commonly required for process equipment and mechanical machinery. Solid Edge Structural Frames and Solid Edge Weldments are part of the core design capabilities of Solid Edge and feature the same user-friendly process-oriented workflows that have made Solid Edge the most intuitive and productive solid modeling program available.

Solid Edge Structural Frames and Solid Edge Weldments incorporate industry intelligence and use the terminology common to their disciplines. Embedded engineering process knowledge, along with structured workflows, help you design frames and weldments much faster than with general-purpose CAD modeling tools. Streamlined modeling commands are tailored to the unique needs of the tasks for maximum modeling speed.

Solid Edge Structural Frames and Solid Edge Weldments are fully associative with Solid Edge assembly, part modeling and drafting capabilities. Because these applications are core capabilities of Solid Edge, users can leverage the exclusive Solid Edge cPDM and design management capabilities integrated directly into the CAD system to enhance collaboration, speed decisions and ensure that users are always working with the most current version of a design.

Solid Edge Structural Frames and Solid Edge Weldments act together to provide a workflow that speeds the design, validation and documentation of welded frames, making Solid Edge the best choice for machinery and process equipment design. This paper explores how these applications are used and how much time they save compared to traditional design methods for welded frames.

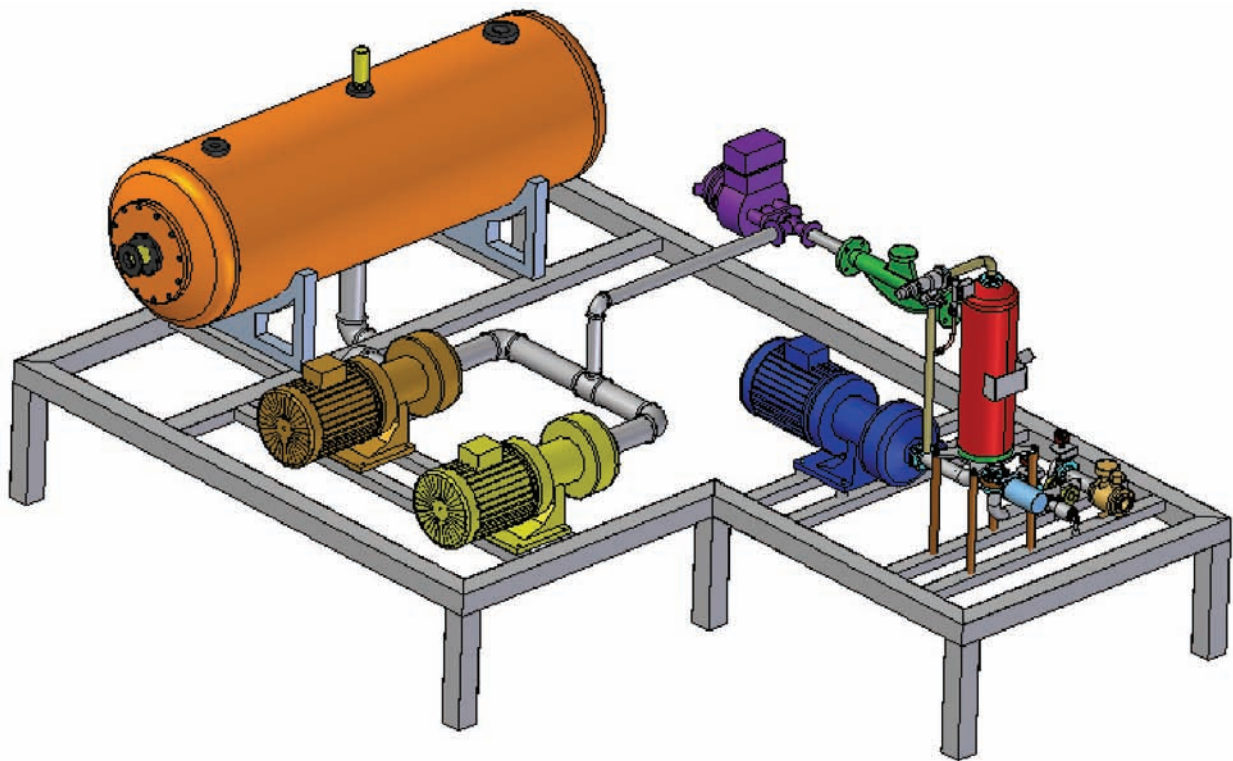

► Solid Edge structural frames

Solid Edge Structural Frames is a process-specific workflow that helps users develop rigid frame structures. An intuitive interface guides a user through the process of creating a 3D sketch of the frame skeleton, modifying default features, applying standard structural cross-sections and then automatically generating a 3D solid model of the frame.

Creating the frame skeleton

The Structural Frames workflow is initiated from the assembly environment. During this step, you create the skeleton, which delivers a fully associative path for the frame section to follow. This step uses the same tools that have been developed for the Solid Edge XpresRoute application, which let you specify these paths quickly by defining 3D variational sketches using specialized modeling aids, such as OrientXpres.

OrientXpres is an interactive design aid that assists in drawing the 3D lines and arcs that the frame members will follow. Both straight and curved frame paths are supported, so you can define frame components to be linear, curved or bent. As you draw line or arc segments, you can use OrientXpres to lock the orientation of the segment parallel to an axis or plane.

You can also associate path segments to existing assembly geometry using standard Solid Edge relationships, such as parallel, perpendicular and colinear. As with 2D sketches, you can define the size of the segments using dimensions, variables or other constraints to set relationships, such as making two frame members equal in length.

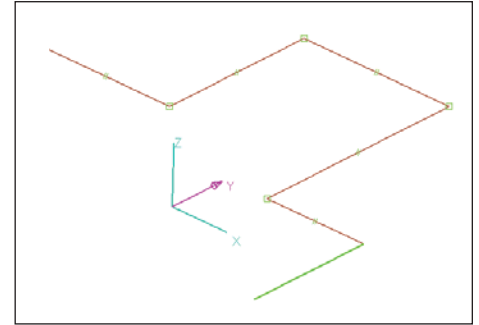

In addition to creating path segments from 2D sketches, you can also use edges and other geometry from 3D parts in the assembly. You also can build frames that have more than two frame members joined at a single vertex, choosing which of several possible solutions you want to use for mitering or cutting each of the frame members.

Building the 3D frame

Once a full or partial frame skeleton has been created, click the frames button. This command lets you build the frame unit by choosing segments of the frame skeleton and selecting specific cross-sections to apply to those segments.

After clicking on the desired path geometry, you can either select a cross-section from the recently used pulldown list in the SmartStep ribbon bar, or browse the standard library components to specify the frame component type and size. Solid Edge is delivered with a complement of frame sizes in its Standard Parts application, with many more available in the optional Solid Edge Machinery Library. Solid Edge supports the most common cross-sectional shapes, as well as many others such as T, hexagonal, Z and flats. Most of the major standards (for example, ANSI, DIN, ISO, GB, JIS) for frame components are

supported. You also can add your own custom components to the library (see Solid Edge Help for details on how to do this), and use them in exactly the same manner.

After selecting the relevant cross-sections, Solid Edge automatically creates the 3D model of the frame by applying those sections to the chosen path segments and using the end treatment options specified in the initial frame dialog. You have a number of different end conditions to choose from – miter, butt1, butt2 or none. The miter and none options are self explanatory. With a butt1 condition, the longest member will be trimmed against (the shortest member will have material removed to suit). A butt2 condition is the opposite, with the shortest member being trimmed against. You can mix and match frame component sizes and shapes and their end condition treatments; any combination is possible.

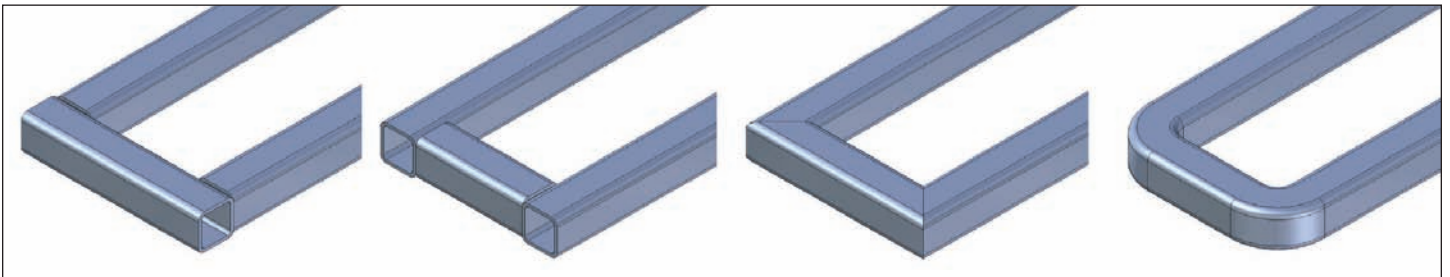

At this point, you can either click the finish button on SmartStep, or make any necessary edits to the path step, frame cross-sections or frame end conditions for the set of components you have just created. If you finish, you can then continue to add more frame members to the path geometry. Subsequent frames will be trimmed against existing frame components, giving you the ability to mix and match sizes and shapes of frame components in any combination.

A nice feature of this workflow is the built-in support for automatic positioning. As you continue to add components to the overall frame, those individual components will analyze any existing, adjacent frame components to determine their correct location and orientation. If the automatically chosen position is incorrect, you can quickly shift the component using the n key to rotate in 90° increments, or the arrow keys to shift upward, downward, left or right.

You can also select frame components and use standard SmartStep methodology to click back through any of the creation steps to edit a frame that you have already created. In this way, you can add or remove path segments, select new frame cross-section types or sizes, or change end treatments globally (for the whole frame) or locally (for a single vertex). After making edits, the frame will immediately be recomputed to show the changes.

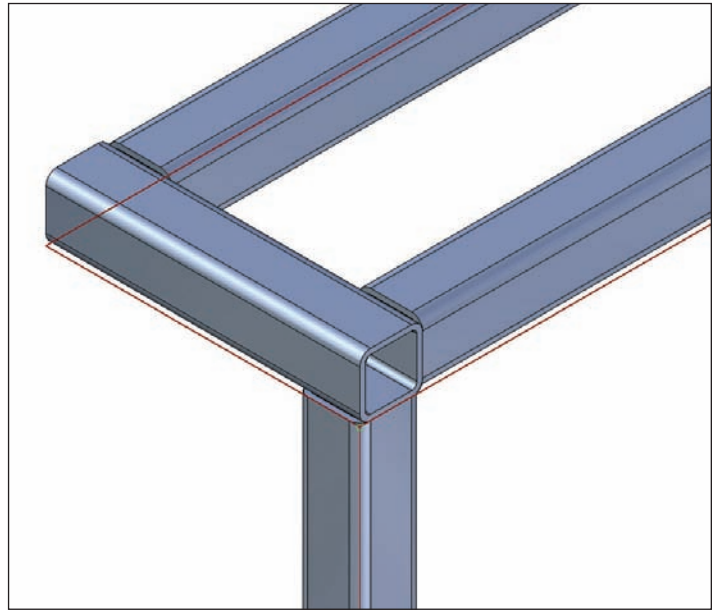

Item #	Document Number	Qty.	Cut Length
12	Pipe ANSI B36.19M - 3 x 0,120	1	393.62 mm
13	Pipe ANSI B36.19M - 1 1/2 x 0,109	1	856.93 mm
14	Pipe ANSI B36.19M - 3 x 0,120	1	223.88 mm
15	Pipe ANSI B36.19M - 3 x 0,120	1	204.37 mm
16	Pipe ANSI B36.19M - 3 x 0,120	1	133.37 mm
17	Pipe ANSI B36.19M - 3 x 0,120	1	452.02 mm
18	Pipe ANSI B36.19M - 3 x 0,120	1	410.27 mm
19	Pipe ANSI B36.19M - 1 1/2 x 0,109	1	216.33 mm
20	Pipe ANSI B36.19M - 1 1/2 x 0,109	1	258.51 mm
21	Pipe ANSI B36.19M - 1 1/2 x 0,109	1	210.89 mm
22	Pipe ANSI B36.19M - 1 1/2 x 0,109	1	343.83 mm
23	Pipe ANSI B36.19M - 1 1/2 x 0,109	1	260.48 mm
24	Pipe ANSI B36.19M - 3 x 0,120	1	273.74 mm
25	Pipe ANSI B36.19M - 3 x 0,120	1	223.46 mm
26	Pipe ANSI B36.19M - 3 x 0,120	1	271.66 mm
27	Elbow 90° Class 150 ASME B16.3 - 1 1/2	3	
28	Flange Class 125 ASME B16.1 - 1 1/2	1	
29	Elbow 90° Class 150 ASME B16.3 - 3	6	
30	Tee Reducing Class 150 ASME B16.3 - 3 x 3 x 1 1/2	1	
31	Flange Class 125 ASME B16.1 - 3	2	

Item #	Title	Qty.	Cut Length
1	SQUARE TUBING 80x80x5	1	1380.00 mm
2	SQUARE TUBING 80x80x5	1	1472.00 mm
3	SQUARE TUBING 80x80x5	1	3800.00 mm
4	SQUARE TUBING 80x80x5	1	2408.00 mm
5	SQUARE TUBING 80x80x5	1	2600.00 mm
6	SQUARE TUBING 80x80x5	1	1300.00 mm
7	C CHANNEL 80x45	2	1518.20 mm
8	C CHANNEL 80x45	4	1220.00 mm
9	SQUARE TUBING 80x80x5	1	2440.00 mm
10	SQUARE TUBING 80x80x5	2	649.80 mm

Create drawings with cut lists

As with all process-specific functionality in Solid Edge, full support is provided for creating drawings of 3D frames. You can automatically create a parts list that includes cut lengths for each component and choose how you want to organize the list for downstream viewers in manufacturing or purchasing. Solid Edge also supports the concept of “rough cut” sizing, allowing you to specify an amount that will be added to the exact length of frame. For example, the exact length of a frame may be 36 inches, but you need the parts list to display 36 inches or the “rough cut” length. In this case, you simply specify a rough cut value of a half inch to be added to the exact length of each frame component.

► Solid Edge weldments

Through close cooperative work with our customers and talking to welding engineers, we have developed Solid Edge Weldments to provide process-driven tools to speed up time-to-manufacture. Solid Edge Weldments complements (but is not limited to) Solid Edge Structural Frames by providing a process-specific workflow for the efficient construction of weldments, using a frame assembly document as input. A weldment is started directly within a Solid Edge assembly where process-specific tools are used to add true weldment information, adding surface preparation features, defining weld bead features and weld characteristics, and specifying final post-weld features. Weld bead and machining operations and weldment operations are organized in the native assembly tree within EdgeBar.

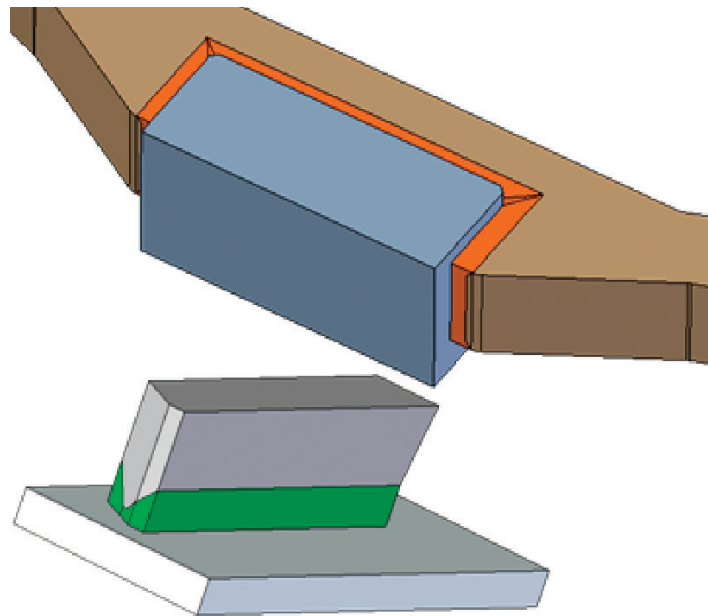

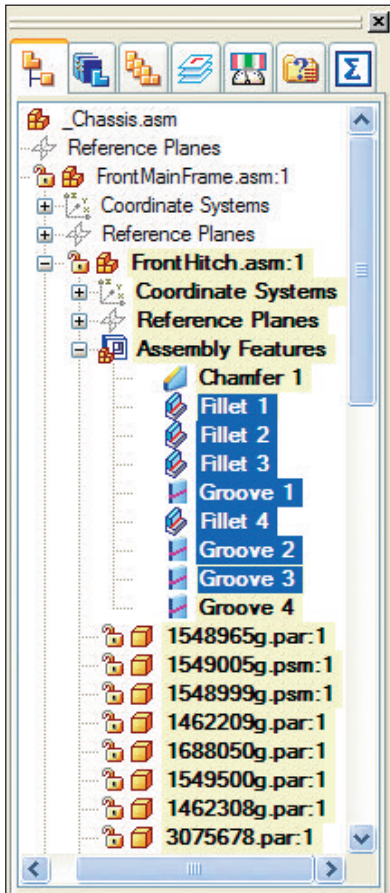

Creation and selection of the weldment

The process begins by marking a Solid Edge assembly as a weldment using the Weldment Assembly command. Because you remain in the assembly, you maintain all the advantages such as color, styles, configurations, product structure and managed data in a single file. The weldment is assigned properties for bead material, style and density. These properties are applied to the weld as they are created. By assigning a material density, weight is automatically added to the assembly, providing accurate mass calculations. Companies are able to use the weld bead mass calculations to help estimate costs (many companies estimate the cost of welding based on weld bead mass). As soon as the assembly is marked as a weldment, a process-specific toolbar is presented, for weld preparation, adding weld material and post-weld machining operations.

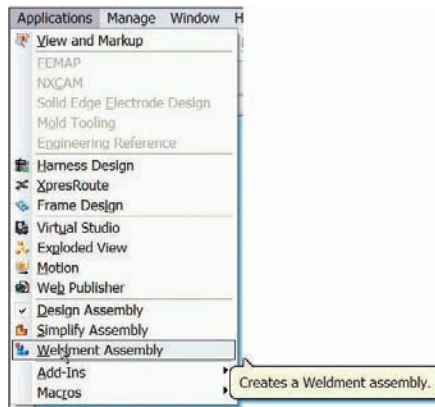

Surface preparation

Many welded joints use weld preparation to strengthen them. On thin gauged materials such as sheet metal, up to about 3mm thick, a simple gap of about the material thickness is usually all that is required. On thicker materials different types of weld preparation are normal; 'V', 'J' and 'U' preps are used depending on the material and the joint type. Solid Edge provides assembly feature tools, such as chamfer, cutout and swept cutout to create weld preparation details on the edges where parts are to be welded together. These do not affect the parts in the original frame assembly document.

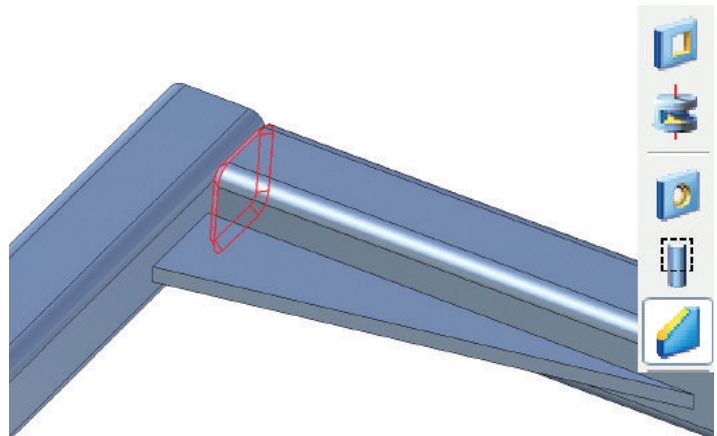

Weld bead creation

Solid Edge provides many tools to easily create the weld bead material depending on the weld type required and joint preparation.

Fillet welds. The most common type of weld is the fillet weld. Following a simple process, all you have to do is choose the two faces that are going to be welded together. Solid Edge automatically creates the familiar triangular shaped weld bead associated with this weld type; predefined parameters for each leg length and offset, size and style are used.

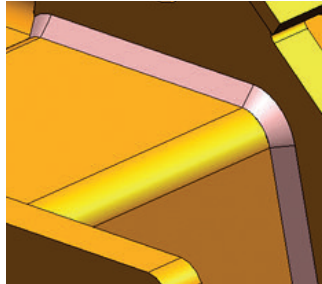

Customized welds. Not all welds are simply triangular in shape; some beads need to represent a specific cross-section, either because of the weld specification or preparation type. Assembly feature tools – protrusion, revolved and sweep protrusions – are available so that users can define their required weld bead cross-section.

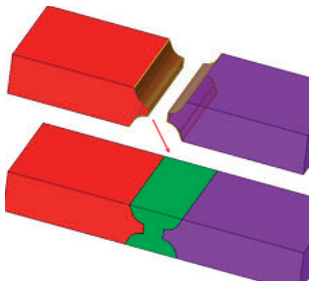

Groove weld. For joint types with shaped weld preparations, the groove weld bead provides great flexibility whereas other methods do not support such a bridging gap. You can quickly add weld beads to components with complex boundaries or weld preparation on both sides of the joint. The process for creating a

groove weld is simple – choose the faces to apply the weld, select the boundary where the weld preparation is to be contained and the groove weld is complete. Additional extent options allow you to control how the groove weld extends along the weld, or cross-sectional profile.

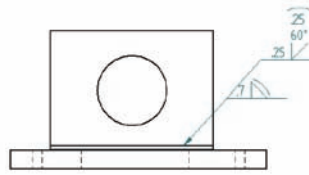

Compound weld. Many welded joints consist of multiple weld beads or runs as they are sometimes known, which overlay each other to strengthen a joint. The compound weld bead

command allows designers to add welds on top of other weld beads, and then label them. When a compound weld is labeled, it can then be extracted on the drawing to provide detailed annotations on drawings.

Stitch weld. Where strength or gas tightness is not a priority, stitch welds are used to save time and materials. The Stitch Weld command provides a dedicated tool to apply stitch welds to join components. Options allow you to control the stitch length, gap size, style and offset values for perfect control.

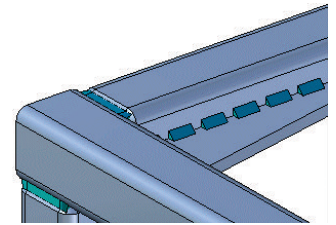

Mirror and patterning. To help speed up the weldment process, weldments can be patterned or mirrored to other areas of the weldment.



Weld label. The weld label enables you to define the weld symbol attributes you want. Additional weld annotations are added to the 3D solid weld bead. The weld label is used to build a weld symbol, to define the weld specification and add it to the 3D model. Details such as weld process, joint type, weld bead type and standard can be defined. Settings can be saved to use later. Labels can be retrieved in the drawing when weld symbols are present. A weld texture gives a more realistic appearance.



► Machining

Once the weld has been added to a weldment, it is common to undertake post-weld machining – for example, machining off excess weld or guaranteeing holes through multiple parts are coaxial.

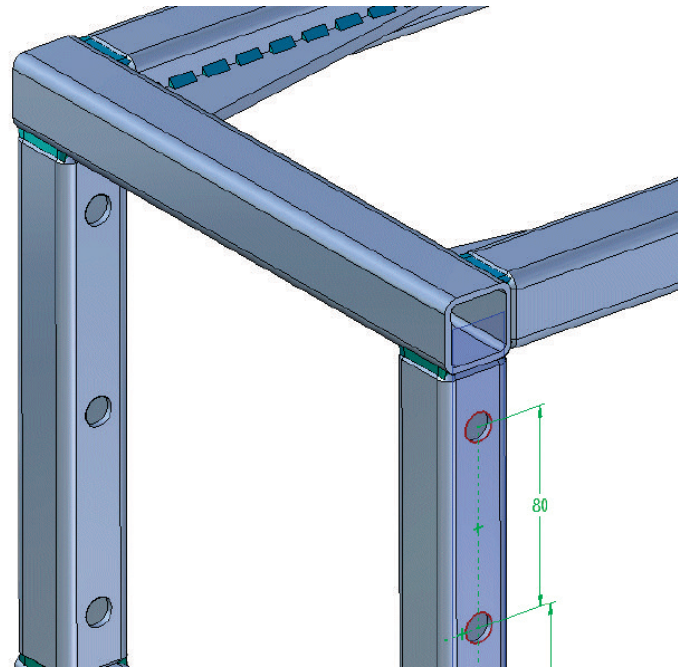

► Drawings and documentation

Weldments are supported in Solid Edge Draft, allowing the following views of the frame assembly: pre-weld view, post-weld view and post-machine view. While working in Draft, you also can retrieve weld labels placed in the weldment environment. The weldment is indicated on the product structure for the frame assembly and is listed in its bill of materials.

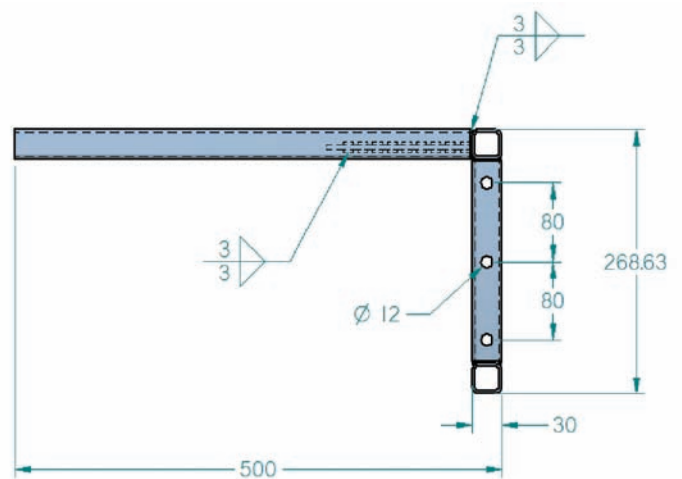

▶ The Solid Edge advantage

Solid Edge Weldments greatly simplifies the creation of welded assemblies. It also streamlines the process of creating a weldment, such as weld documentation and post-weld machining using process-specific features and modeling steps. For example, Solid Edge Weldments supports process configurations (pre-weld, post-weld and machined) for drawing creation. The software provides mirror and pattern support of weld beads and machining features.

Solid Edge Weldments complements the capabilities of Solid Edge Structural Frames to give you a comprehensive solution for creating structural frames. The weldments application allows you to quickly add welds to a previously created frame assembly, without altering the components of the original assembly document. For example, surface preparation is done within the weld environment so that these alterations do not affect the original parts.

As with all Solid Edge applications, Solid Edge Weldments streamlines the creation of the weldments through the use of an intelligent workflow. The software guides you through the steps of creating a weldment, allowing you to do much of the work through simple menu picks and dialog boxes. In addition, there is enough flexibility built into the application to give you the freedom to work in the manner that you prefer.

▶ Summary

Solid Edge Structural Frames and Solid Edge Weldments extend the intuitive, workflow-facilitated nature of Solid Edge CAD to the creation of structural frames and weldments. These two environments streamline these processes, from design of the components to their documentation and their use downstream. With these two powerful environments, Solid Edge confirms its role as the most complete, intuitive design-through-fabrication solution. Designers of machinery and process equipment can take advantage of these powerful capabilities within Solid Edge to shrink product lead times, improve quality and reduce costs.

About Siemens PLM Software

Siemens PLM Software, a business unit of the Siemens Industry Automation Division, is a leading global provider of product lifecycle management (PLM) software and services with 5.5 million licensed seats and 51,000 customers worldwide. Headquartered in Plano, Texas, Siemens PLM Software's open enterprise solutions enable a world where organizations and their partners collaborate through Global Innovation Networks to deliver world-class products and services. For more information on Siemens PLM Software products and services, visit www.siemens.com/plm.

► For more information, contact your local Solid Edge representative:



DESTEK
YAZILIM

Destek Yazılım Ltd. Şti.
Barbaros Mah. Denizmen Sk.
No:4/2 Koşuyolu – Usküdar
34662 İstanbul
Tel: (0216) 651 98 01
Fax: (0216) 651 98 02
www.destek-yazilim.com

SIEMENS

Division headquarters

United States

Granite Park One
5800 Granite Parkway
Suite 600
Plano, TX 75024
972 987 3000
Fax 972 987 3398

Solid Edge – www.siemens.com/solidedge

Americas

800 807 2200
Fax 314 264 8922

Europe

44 (0) 1202 243455
Fax 44 (0) 1202 243465

Asia-Pacific

852 2230 3308
Fax 852 2230 3210